

AFB

AFB BAG FILTER

Suitable for non-hazardous fluid

Amafilter® offer a wide range of bag filter housings. AFB bag filter housings are an easy to use and cost effective product for the filtration of liquids containing higher concentrations of coarse solids.

They are particularly beneficial when handling batches of various liquids. Amafilter® bag filter housings can be used as end-filtration or for the polishing of liquids with extremely low concentrations of solids.

FEATURES

- Easy to operate and to access.
- Effective interior sealing.
- The cover closure has hinged eye bolts and eye nuts in galvanised steel. Stainless steel bolts and nuts are optional.
- Flat cover with handle.
- O-ring sealing: standard Buna N. Other materials available on demand.
- Durable stainless steel metal mesh support basket for low flow resistance and maximum utilisation of entire surface area.
- Slightly conical support basket for easy filter bag removal.
- Liquid displacement cover: leak proof for complete seal when opening the filter.
- Liquid displacer units are available to further reduce the dead volume inside the filter bags.
- Perfect sealing between unfiltered liquid and filtered liquid is achieved by a spring-loaded hold-down device onto the filter bag and support basket. The filter bag seals with a feltcovered snap-collar ring or plastic seal which tightly fits into the support basket.
- Height-adjustable legs.
- The maximum temperature for these housings is 90 °C.
- Height adjustable legs.
- Liquid displacement cover design: no liquid runs over the side when opening the filter. Safe and clean operation.



STANDARD SPECIFICATIONS

Design pressure:	0 / 10 bar(g)
Design temperature:	0 / 90 °C
Operating temperature:	depending on the filter media and gaskets used
PED 2014/68/EU:	article 4 paragraph 3

MAXIMUM DIFFERENTIAL PRESSURE

Design:	4.0 bar
Operating:	2.5 bar

FILTER BAGS

Amafilter® supplies a wide range of filter bags in different materials, pore sizes, dimensions and models to fit in our range of bag filter housings as well as those of other manufacturers.

OPTIONS

Strainer baskets

The filter housings can be equipped with stainless steel filter baskets in several mesh sizes. The filter housings can then be used as strainers.

Special models to suit customer requirements

Other options of supply and manufacture are non-standard types for higher temperatures, pressures and other materials according to current design codes, available on request.

DIMENSIONS

Nozzle specification

N1 : Inlet

N2 : Outlet

N3 : Vent (Rp ¼ - ISO7-1)

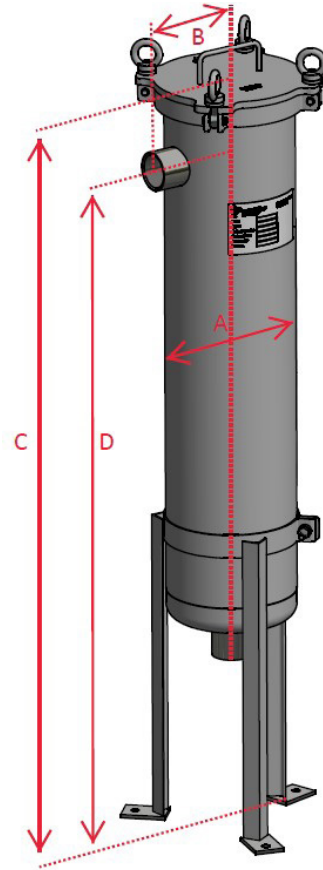

DIMENSIONAL INFORMATION

SIZE	DIAMETER A	STANDOUT B	HEIGHT C	NOZZEL HEIGHT D	VOLUME	WEIGHT
mm	mm	mm	mm	mm	dm ³	kg
90	219	156 MAX.	1020 MAX.	895	19	MAX. 21
180	219	THREADED: 156 FLANGED: 210	1370 MAX.	MAX. 1245	34	MAX. 33

Dimensions are for reference only. Use dimensional drawing for installation purposes.
Subject to technical alteration without prior notice.

ORDERING CODE

AFB 180	-	T	-	2F
Type Size		Material		Inlet/Outlet
90 = for bag size 1		No symbol = carbon steel		2 = Rp2 - ISO7-1
180 = for bag size 2		T = 316Ti (1.4571)		2F = DN50 acc. EN1092/PN16
		TY = 316Ti (1.4571) with stainless steel bolts and nuts		
				Size 180 Only
				2B = Ø52.1x1.5 acc. DIN11850
				3F = DN80 acc. EN1092/PN16
				ASME B16.5 150 lbs RF on request (FA)

04/01/2024



Scan QR Code to find our locations
+31 573 297 777
info.fgnl@filtrationgroup.com
www.amafiltration.com